



ICSE QUESTION PAPER

CHEMISTRY

(2007)

SECTION—I (40 Marks)

(Compulsory : Attempt all questions.)

Question 1.

- (a) From the list given below, select the word(s) required to correctly complete blanks (i) to (v) in the following passage :

ammonia, ammonium, carbonate, carbon dioxide, hydrogen, hydronium, hydroxide, precipitate, salt, water.

A solution X turns blue litmus red, so it must contain (i) ions; another solution Y turns red litmus blue and therefore, must contain (ii) ions. When solutions X and Y are mixed together, the products will be a (iii) and (iv) If a piece of magnesium were put into solution X, (v) gas would be evolved. [5]

(Note : words chosen from the list are to be used only once. Write the answers as (i) (i), (ii) (ii) and so on. Do not copy the passage).

- (b) From the list of characteristics given below, select the five which are relevant to non-metals and their compounds :

- | | |
|--|------------------------------|
| A Ductile | B Conduct electricity |
| C Brittle | D Acidic oxides |
| E Basic oxides | F Discharged at anode |
| G Discharged at cathode | H Ionic Chlorides |
| I Covalent Chlorides | |
| J Reaction with dilute Sulphuric acid yields hydrogen | |
| K 1, 2 or 3 valence electrons | |
| L 5, 6 or 7 valence electrons | |

(Write the five letters corresponding to the correct characteristics) [5]

- (c) A group of elements in the Periodic Table are given below (Boron is the first member of the group and Thallium is the last).

Boron, Aluminium, Gallium, Indium, Thallium

Answer the following questions in relation to the above group of elements :

- Which elements has the most metallic character ?*
- Which element would be expected to have the highest electro-negativity ?*
- If the electronic configuration of Aluminium is 2, 8, 3, how many electrons are there in the outer shell of Thallium ?*
- The atomic number of Boron is 5. Write the chemical formula of the compound formed when Boron reacts with Chlorine.*
- Will the elements in the group to the right of this Boron group be more metallic or less metallic in character ? Justify your answer.* [5]



(d) Match the following :

Column A

1. Acid salt
2. Mixed salt
3. Complex salt
4. Double salt
5. Normal salt

Column B

- A. Sodium potassium carbonate
- B. Alum
- C. Sodium carbonate
- D. Sodium zincate
- E. Sodium hydrogencarbonate [5]

(e) Give the IUPAC names of the following compounds numbered (i) to (v). The IUPAC names of the compounds on the left are to guide you into giving the correct IUPAC names of the compounds on the right.

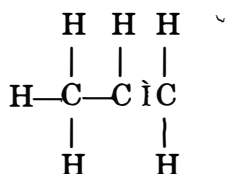

Propene

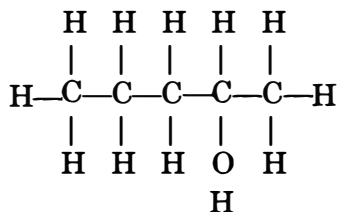

Pentan-2-ol

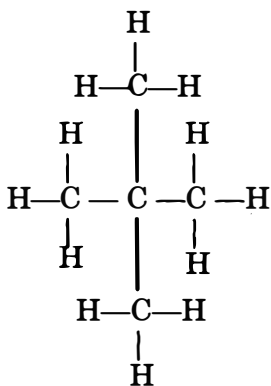

2, 2-dimethylpropane

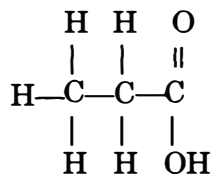

Propanoic acid

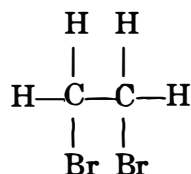

1, 2-dibromoethane

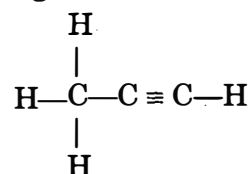

(i)

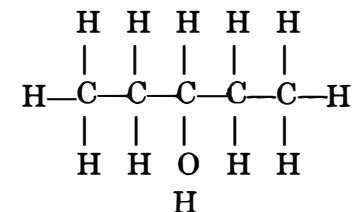

(ii)

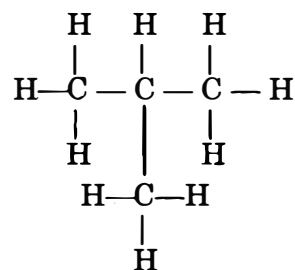

(iii)

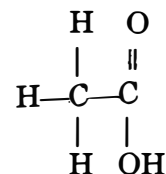

(iv)

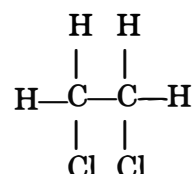

(v)

[5]



- (f) A sample of ammonium nitrate when heated yields 8.96 litres of steam (measured at stp).

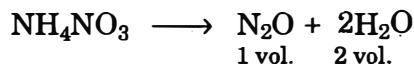

- (i) What volume of dinitrogen oxide is produced at the same time as 8.96 litres of steam ?
- (ii) What mass of ammonium nitrate should be heated to produce 8.96 litres of steam ? (Relative molecular mass of ammonium nitrate is 80).
- (iii) Determine the percentage of oxygen in ammonium nitrate (O = 16) [5]
- (g) Write balanced chemical equations for the following reactions :
- (i) Lead sulphate from lead nitrate solution and dilute sulphuric acid.
- (ii) Copper sulphate from copper and concentrated sulphuric acid.
- (iii) Lead chloride from lead nitrate solution and sodium chloride solution.
- (iv) Ammonium sulphate from ammonia and dilute sulphuric acid.
- (v) Sodium chloride from sodium carbonate solution and dilute hydrochloric acid. [5]
- (h) Choose A, B, C or D to match the descriptions (i) to (v) below. Some alphabets may be repeated.

A non-electrolyte

B strong electrolyte

C weak electrolyte

D metallic conductor

(i) Molten ionic compound.

(ii) Carbon tetrachloride

(iii) An aluminium wire

(iv) A solution containing solvent molecules solute molecules and ions formed by the dissociation of solute molecules.

(v) A sugar solution with sugar molecules and water molecules. [5]

Answer.

(a) (i) hydronium (ii) hydroxide (iii) salt

(iv) water (v) Hydrogen.

(b) C, D, F, I, L.

(c) (i) Thallium (ii) Boron

(iii) Three (iv) BCl_3 .

(v) Less metallic. Because on moving towards right in periodic table metallic character decreases.

(d) 1.—E. 2.—A. 3.—D. 4.—B. 5.—C.

(e) (i) Propyne (ii) Pentan-3-ol

(iii) 2-methyl propane (iv) Ethanoic acid

(v) 1, 2-dichloroethane

(f) (i) $\text{NH}_4\text{NO}_3 \longrightarrow \underset{1 \text{ vol}}{\text{N}_2\text{O}} + \underset{2 \text{ vol}}{2\text{H}_2\text{O}}$

When 2 vol. of steam is produced, 1 vol. of N_2O is formed.

\therefore When steam produced is 8.96 lit.

$$\text{Vol. of } \text{N}_2\text{O} = \frac{8.96}{2} = 4.48 \text{ litre.}$$

Ans.

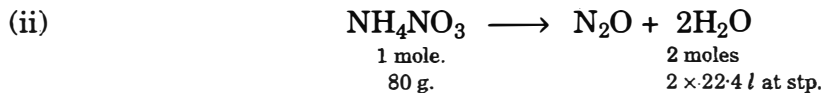

Since 2×22.4 l of steam is produced from 80g of NH_4NO_3 .

8.96 l of steam will be produced from $\frac{80 \times 8.96}{2 \times 22.4} = 16$ g. of NH_4NO_3 **Ans.**

(iii) % of oxygen in $\text{NH}_4\text{NO}_3 = \frac{3 \times 16 \times 100}{80} = 60\%$. **Ans.**

- (g) (i) $\text{Pb}(\text{NO}_3)_2 + \text{H}_2\text{SO}_4 \longrightarrow \text{PbSO}_4 + 2\text{HNO}_3$
(ii) $\text{Cu} + 2\text{H}_2\text{SO}_4 \longrightarrow \text{CuSO}_4 + 2\text{H}_2\text{O} + \text{SO}_2$
(iii) $\text{Pb}(\text{NO}_3)_2 + 2\text{NaCl} \longrightarrow \text{PbCl}_2 + 2\text{NaNO}_3$
(iv) $2\text{NH}_3 + \text{H}_2\text{SO}_4 \longrightarrow (\text{NH}_4)_2\text{SO}_4$
(v) $\text{Na}_2\text{CO}_3 + 2\text{HCl} \longrightarrow 2\text{NaCl} + \text{H}_2\text{O} + \text{CO}_2$
- (h) (i) —B strong electrolyte (ii) —A non-electrolyte
(iii) —D metallic conductor (iv) —C weak electrolyte
(v) —A non-electrolyte

Section—II (40 marks)

(Answer any **four** questions from this section)

Question 2.

- (a) Some properties of Sulphuric acid are listed below. Choose the property A, B, C or D which is responsible for the reactions (i) to (v). Some properties may be repeated :

- A Acid B Dehydrating agent
C Non-volatile acid D Oxidizing agent

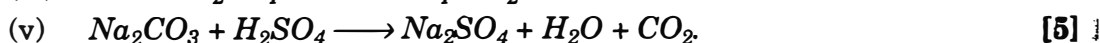
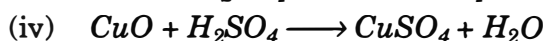
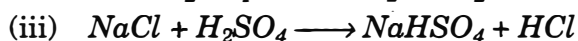
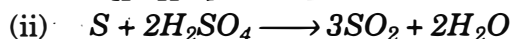
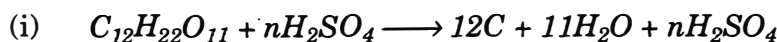

- (b) (i) Name the acid formed when sulphur dioxide dissolves in water. **
(ii) Name the gas released when sodium carbonate is added to a solution of sulphur dioxide. **
(iii) What are the two necessary conditions for the direct combination of sulphur dioxide and chlorine forming sulphuryl chloride? **
(iv) State the property of sulphur dioxide which causes potassium permanganate to change its colour from purple to colourless. ** **[5]**

Answer.

- (a) (i) —B. (ii) —D. (iii) —C. (iv) —A. (v) —A.

Question 3.

- (a) (i) Of the two gases, ammonia and hydrogen chloride, which is more dense? Name the method of collection of this gas.
(ii) Give one example of a reaction between the above two gases which produces a solid compound. **[3]**



(b) Write a balanced equation for a reaction in which ammonia is oxidized by :

- a metal oxide;
- a gas which is not oxygen.

[2]

(c) The figure given below illustrates the apparatus used in the laboratory preparation of nitric acid.

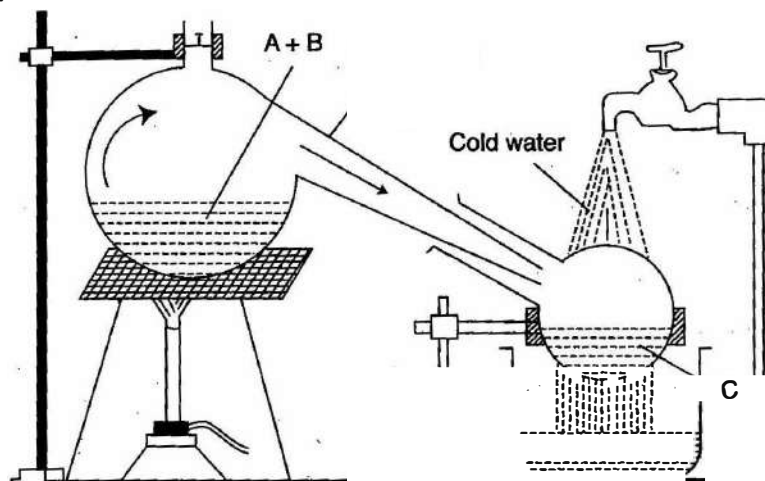

(i) Name A (a liquid), B (a solid) and C (a liquid).

(Do not give the formula)

(ii) Write an equation to show how nitric acid undergoes decomposition.

Write the equation for the reaction in which copper is oxidized by concentrated nitric acid. [5]

Hydrogen chloride is more dense. It is collected by upward displacement of air.

(ii) Hydrogen chloride and ammonia gas react together to give solid ammonium chloride. $\text{NH}_3 + \text{HCl} \longrightarrow \text{NH}_4\text{Cl}$

(b) (i) $3\text{CuO} + 2\text{NH}_3 \longrightarrow 3\text{Cu} + \text{N}_2 + 3\text{H}_2\text{O}$

(ii) $2\text{NH}_3 + 3\text{Cl}_2 \longrightarrow 6\text{HCl} + \text{N}_2$

(c) (i) A → Conc. Sulphuric acid, B → Potassium Nitrate, C → Nitric acid.

(ii) $4\text{HNO}_3 \longrightarrow 2\text{H}_2\text{O} + 4\text{NO}_2 + \text{O}_2$

(iii) $\text{Cu} + 4\text{HNO}_3 \longrightarrow \text{Cu}(\text{NO}_3)_2 + 2\text{H}_2\text{O} + 2\text{NO}_2$

Question 4.

(a) The following is an extract from 'Metals in the Service of Man, Alexander and Street / Pelican 1976' :

'Alumina (aluminium oxide) has a very high melting point of over 2000°C so that it cannot readily be liquefied. However, conversion of alumina to aluminium and oxygen, by electrolysis, can occur when it is dissolved in some other substance.'

(i) Which solution is used to react with bauxite as a first step in obtaining pure aluminium oxide ?

(ii) The aluminium oxide for the electrolytic extraction of aluminium is obtained by heating aluminium hydroxide. Write the equation for this reaction.



- (iii) Name the element which serves both as the anode and the cathode in the extraction of aluminium.
- (iv) Write the extraction of aluminium by electrolysis.
- (v) Give the equation for the reaction which occurs at the anode when aluminium is purified by electrolysis. [5]
- (b) (i) Name the charged particles which attract one another to form electrovalent compounds.
- (ii) In the formation of electrovalent compounds, electrons are transferred from one element to another. How are electrons involved in the formation of a covalent compound ?
- (iii) The electronic configuration of nitrogen is 2, 5. How many electrons in the outer shell of a nitrogen atom are not involved in the formation of a nitrogen molecule ?
- (iv) In the formation of magnesium chloride (by direct combination between magnesium and chlorine), name the substance that is oxidized and the substance that is reduced. [5]

Answer.

- (a) (i) Sodium hydroxide solution. (ii) $2\text{Al}(\text{OH})_3 \longrightarrow \text{Al}_2\text{O}_3 + 3\text{H}_2\text{O}$
- (iii) Carbon. (iv) $\text{Al}^{+++} + 3\text{e}^- \longrightarrow \text{Al}$
- (v) $\text{Al} \longrightarrow \text{Al}^{+++} + 3\text{e}^-$
- (b) (i) Cations and anions. (ii) Electrons are shared.
- (iii) Two electrons.
- (iv) Magnesium is oxidised, chlorine is reduced.

Question 5.

Copy and complete the following table relates to three homologous series of Hydrocarbons : [10]

| General Formula | C_nH_{2n} | $\text{C}_n\text{H}_{2n-2}$ | $\text{C}_n\text{H}_{2n+2}$ |
|--|---------------------------|-----------------------------|-----------------------------|
| IUPAC name of the homologous series | | | |
| Characteristic bond type | | | Single bonds |
| IUPAC name of the first member of the series | | | |
| Type of reaction with Chlorine | | Addition | |

Answer.

| General Formula | C_nH_{2n} | $\text{C}_n\text{H}_{2n-2}$ | $\text{C}_n\text{H}_{2n+2}$ |
|--|---------------------------|-----------------------------|-----------------------------|
| IUPAC name of the homologous series | Alkenes | Alkynes | Alkanes |
| Characteristic bond type | Double | Triple | Single bonds |
| IUPAC name of the first member of the series | Ethene | Ethyne | Ethane |
| Type of reaction with Chlorine | Addition | Addition | Substitution. |

**Question 6.**

- (a) (i) HCl , HNO_3 and H_2SO_4 are the formula of three compounds.
Which of these compounds has the highest boiling point and which has the lowest ?
- (ii) Dilute hydrochloric acid and dilute sulphuric acid are both colourless solutions. How will the addition of barium chloride solution to each help to distinguish between the two ?
- (iii) You enter a laboratory after a Class has completed the Fountain Experiment. How will you be able to tell whether the gas used in the experiment was hydrogen chloride or ammonia ? [5]
- (b) Write balanced equations for the reaction of dilute hydrochloric acid with each of the following :
- (i) iron (ii) sodium hydrogencarbonate
(iii) iron (II) sulphide (iv) sodium sulphite
(v) sodium thiosulphate solution. [5]

Answer.

- (a) (i) H_2SO_4 has highest boiling point while HCl has lowest boiling point.
(ii) When barium chloride solution is added to dil. hydrochloric acid no ppt is seen but when barium chloride solution is added to dil. sulphuric acid a white ppt is observed.
(iii) If solution in inverted flask is blue, the gas used was ammonia and if solution in inverted flask is red the gas used was hydrogen chloride.
- (b) (i) $Fe + 2HCl \longrightarrow FeCl_2 + H_2$
(ii) $NaHCO_3 + HCl \longrightarrow NaCl + H_2O + CO_2$
(iii) $FeS + 2HCl \longrightarrow FeCl_2 + H_2S$
(iv) $Na_2SO_3 + 2HCl \longrightarrow 2NaCl + H_2O + SO_2$
(v) $Na_2S_2O_3 + 2HCl \longrightarrow 2NaCl + S + H_2O + SO_2$

Question 7.

- (a) A compound X consists of 4.8% carbon and 95.2% bromine by mass.
- (i) Determine the empirical formula of this compound working correct to one decimal place (C = 12; Br = 80).
- (ii) If the vapour density of the compound is 252, what is the molecular formula of the compound ?
- (iii) Name the type of chemical reaction by which X can be prepared from ethane. [5]

Salts A, B, C, D and E undergo reactions (i) to (v) respectively. Identify the anion present in these salts on the basis of these reactions. Tabulate your answers in the format given below :

- (i) When silver nitrate solution is added to a solution of A, a white precipitate, insoluble in dilute nitric acid, is formed.
- (ii) Addition of dilute hydrochloric acid to B produces a gas which turns lead acetate paper black.

**782 | ICSE Last 10 Years Solved Papers**

- (iii) When a freshly prepared solution of ferrous sulphate is added to solution of C and concentrated sulphuric acid is gently poured from side of the test-tube, a brown ring is formed.
- (iv) When dilute sulphuric acid is added to D a gas is produced which turns acidified potassium dichromate solution from orange to green.
- (v) Addition of dilute hydrochloric acid to E produces an effervescence. The gas produced turns limewater milky but does not affect acidified potassium dichromate solution.

| Salt | Anion |
|------|-------|
| A | |
| B | |
| C | |
| D | |
| E | |

[5]

Answer.

- (a)**
- (i) Calculation of Empirical formula

| Element | % age | Relative No. of atoms | Simple ratio |
|---------|-------|-----------------------|---------------|
| Carbon | 4.8 | $4.8/12 = 0.4$ | $0.4/0.4 = 1$ |
| Bromine | 95.2 | $95.2/80 = 1.2$ | $1.2/0.4 = 3$ |

Empirical formula = CBr_3

Ans. 1

- (ii)

$$\begin{aligned} \text{Relative molecular mass} &= \text{VD} \times 2 \\ &= 252 \times 2 \\ &= 504 \end{aligned}$$

$$\begin{aligned} \text{Empirical mass} &= 12 + 80 \times 3 \\ &= 252 \end{aligned}$$

$$n = \frac{504}{252} = 2$$

$$\begin{aligned} \text{Molecular formula} &= (\text{CBr}_3)_2 \\ &= \text{C}_2\text{Br}_6. \end{aligned}$$

Ans. 2

- (iii) By substitution reaction.

| Salt | Anion |
|------|--------------------|
| A | Cl^- |
| B | S^{--} |
| C | NO_3^- |
| D | SO_3^{--} |
| E | CO_3^{--} |